

Uniden® 3162 Series Two-Line Speakerphone User's Guide



Important Information

NOTICE: This product meets the applicable Industry Canada technical specifications.

The equipment must be installed using an acceptable method of connection. The customer should be aware that compliance with the above conditions may not prevent degradation of service in some situations.

Repairs to certified equipment should be made by an authorized Canadian maintenance facility designated by the supplier. Any repairs or alterations made by the user to this equipment, or equipment malfunctions, may give the telecommunications company cause to request the user to disconnect the equipment.

Users should ensure for their own protection that the electrical ground connections of the power utility, telephone lines and internal metallic water pipe systems, if present, are connected together. This precaution may be particularly important in rural areas.

CAUTION: Users should not attempt to make such connections themselves, but should contact the appropriate electric inspection authority, or electrician, as appropriate.

NOTES: This equipment may not be used on coin service provided by the telephone company.

Interference Information

This equipment generates and uses radio frequency energy which may interfere with residential radio and television reception if not properly installed and used in accordance with instructions contained in this manual. Reasonable protection against such interference is ensured, although there is no guarantee this will not occur in a given installation. If interference is suspected and verified by switching this equipment on and off, the user is encouraged to try to correct the interference by one or more of the following measures: Reorient the radio/television receiver's antenna, relocate the equipment with respect to the receiver, plug the equipment and receiver into separate circuit outlets. The user may also wish to consult a qualified radio/television technician for additional suggestions. This equipment has been fully tested and complies with all limits for Class B computing devices pursuant to part 15 FCC Rules and Regulations. This device complies with RSS-210 of Industry Canada. The term "I.C." before the radio certification number only signifies that Industry Canada Technical specifications were met. Operation is subject to the following two conditions: (1) This device may not cause interference, and (2) This device must accept any interference, including interference that may cause undesired operation of the device.

Telephone Network Information

Should your equipment cause trouble on your line which may harm the telephone network, the telephone company, where practicable, may notify you that temporary discontinuance of service may be required. Where prior notice is not practicable and the circumstances warrant such action, the telephone company may temporarily discontinue service immediately.

The telephone company may make changes in its communications facilities, equipment, operations or procedures where such action is required in the operation of its business. If these changes are expected to affect the use or performance of your telephone equipment, the telephone company will likely give you adequate notice to allow you to maintain uninterrupted service.

Notice must be given to the telephone company upon termination of your telephone from your line.

REN Number

On the bottom of this equipment is a label indicating, among other information, the Ringer Equivalence Number (REN) for the equipment.

The REN is useful in determining the number of devices you may connect to your telephone line and still have all of these devices ring when your telephone number is called. In most (but not all) areas, the sum of the RENs of all devices connected to one line should not exceed 5. To be certain of the number of devices you may connect to your line as determined by the REN, you should contact your local telephone company.

REN Number is located on the cabinet bottom.

Hearing Aid Compatibility (HAC)

This telephone system meets FCC/Industry Canada standards for Hearing Aid Compatibility.

Licensing

Licensed under US Patent 6,427,009.

Important Safety Instructions

CAUTION: When using telephone equipment, there are basic safety instructions that should always be followed. Read these instructions carefully and save them for future reference.

- Never install telephone wiring during a lightning storm.
- Never touch uninsulated telephone wires or terminals unless the telephone line has been disconnected at the network interface.
- Use caution when installing or modifying telephone lines.
- Never install telephone jacks in wet locations unless the jack is specifically designed for wet locations.

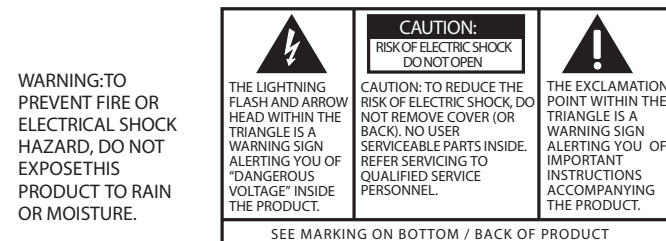

Introduction

Terms Used in This Manual

Hook switch. The part of the phone that pops up to activate the phone line when the handset is lifted from the base.

Line indicator. The light located next to LINE 1 and LINE 2; it shows you the status of each line.

Off-hook. A term used to describe the phone in its active mode when the handset is off of the base cradle or a line button, along with **SPEAKER**, is pressed.

On-hook. A term used to describe the phone in an inactive mode.

Parts Checklist

Make sure your package includes the following items:

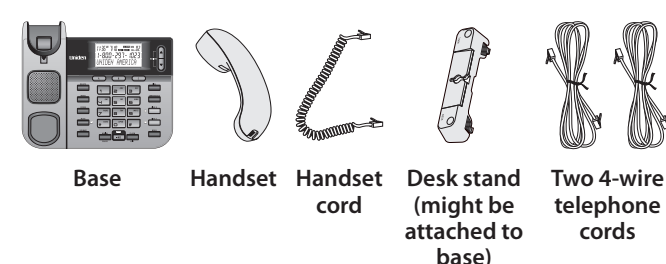

Telephone Jack Requirements

To use this phone, you need an RJ11C type modular telephone jack (shown to the right) installed in your home. If you don't have a modular jack, contact your local phone company to find out how to get one installed.



Installation

Installing and Replacing the Batteries

CAUTION: Before opening the battery compartment, be sure that the telephone is not plugged into a wall jack and that any external equipment (e.g., fax machine, extension phone, etc.) is disconnected from the telephone.

Your phone uses 4 AA-size alkaline batteries for receiving and storing Caller ID records and for storing the numbers you use for memory dialing, pulse dialing, and redial.

You will have approximately 90 seconds to replace the batteries before the memories stored are lost. Please read the instructions before replacing the batteries and have the batteries ready to be inserted beforehand.

If the low battery icon appears in the display, you need to replace the batteries. It is important that you replace the batteries as soon as possible in order to maintain Caller ID operation.

If you are not going to use the telephone for more than 30 days, remove the batteries because they may leak and damage the unit.

- 1) If necessary, disconnect the telephone cord and remove the desk stand. (To remove the desk stand, turn the base over, press in on the tabs and slip them out of the slot.)
- 2) Release the latch on the battery compartment and remove the cover.
- 3) Insert 4 AA-size alkaline batteries as shown on the diagram in the battery compartment.
- 4) Snap the battery compartment door back into place and replace the desk stand.
- 5) Connect the line cord and check your memory locations.

Re-attaching the desk stand

Turn the phone over. Insert the hooks marked **DESK** into the notches marked **DESK**. Press in on the tabs and snap the stand into place.

Connecting the Handset

- 1) Connect one end of the coiled handset cord to the jack on the handset.
- 2) Plug the other end of the coiled handset cord to the jack on the base.
- 3) Place the handset in the cradle.

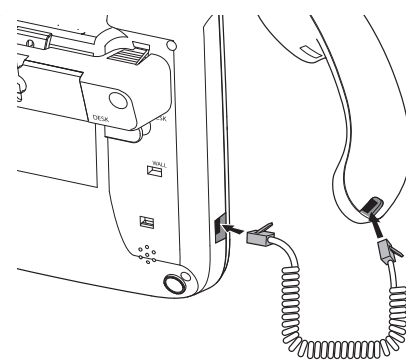

Connecting the Telephone Line

To use two-line features, you must subscribe to two telephone lines from your local phone company. Your phone company might provide these lines on two separate modular jacks or on only one jack (a two-line or four-wire jack); if you have one jack for both lines, the phone company controls which number is line 1.

- 1) Connect one of the included two-line telephone cords to the **LINE 1+2** jack. If your phone company uses a separate phone jack for each line, connect the other telephone cord to the **LINE 2/DATA** jack.

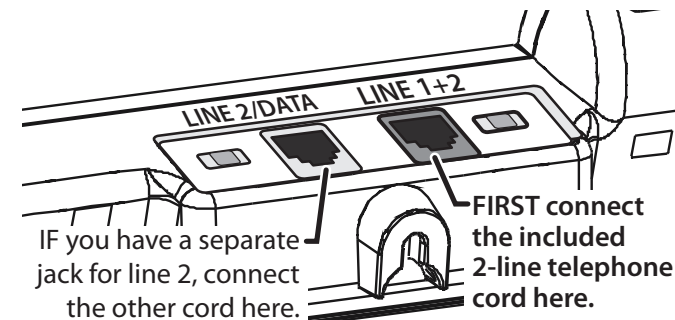

- 2) Connect the cord from **LINE 1+2** to a two-line phone jack.
OR
If your phone company uses a separate phone jack for each line, connect the cord from **LINE 1+2** to the jack for

line 1; then, connect the cord from **LINE 2/DATA** the jack for line 2.

- 3) Set the ringer volume for each line (**RINGER 1** for line 1 and **RINGER 2** for line 2) to the desired loudness. **OFF** - Telephone will not ring. **LO** - Sound will be lowest. **HI** - Sound will be loudest.

The unit is properly installed if you pick up the handset and hear the dial tone. Otherwise, recheck all installation steps.

Data Port

If both of your telephone lines are the same modular jack, you can use the **LINE 2/DATA** jack to connect an auxiliary device, such as a fax machine, computer modem, answering machine, or extension phone. The auxiliary equipment will make and receive calls on line 2 only.

Wall Mounting

Your speakerphone can also be mounted on a wall plate (not included).

To prevent the handset from falling out of the cradle while the phone is hanging on the wall, you must switch both the handset hook and the desk stand to their wall-mount positions.

- 1) On the front of the base, pull the handset hook out of the slot. Rotate the hook 180 degrees and flip it from front to back. Slide it back into the slot.
- 2) Turn the base over and remove the desk stand.

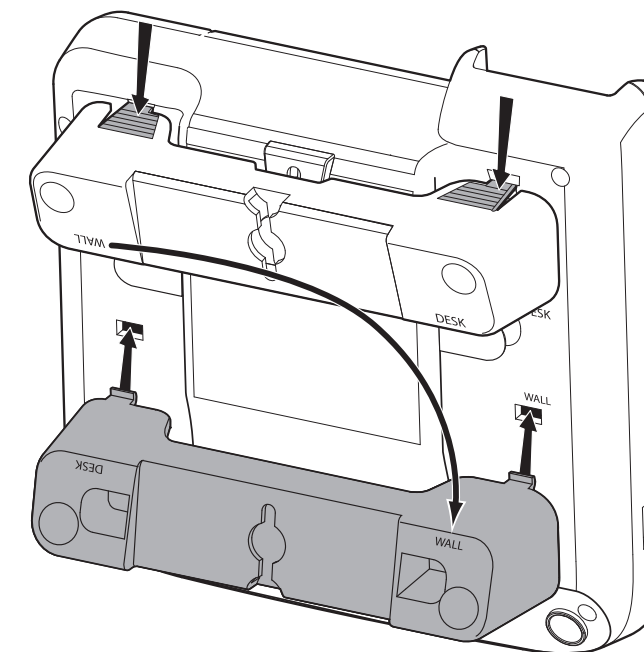
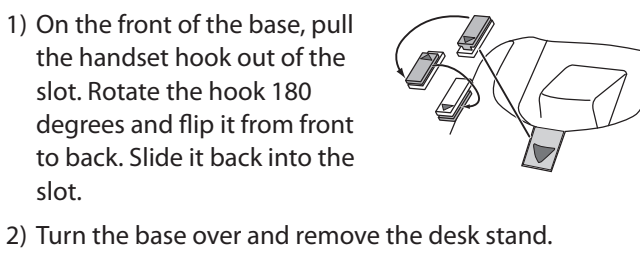

- 3) Rotate the stand 180 degrees, and insert the hooks marked **WALL** into the notches marked **WALL**. Press in on the tabs and snap the stand into place.
 - 4) Connect the two-line telephone cord to the wall jack and the **LINE 1+2** jack on the phone. If desired, wrap any excess cord around the cord hooks as shown.
 - 5) If necessary, connect a cord connected to **LINE 2/DATA**, and pull it up out of the way.
- Place the mounting slots over the pins on the wall plate, and slide the base down to lock it into place.

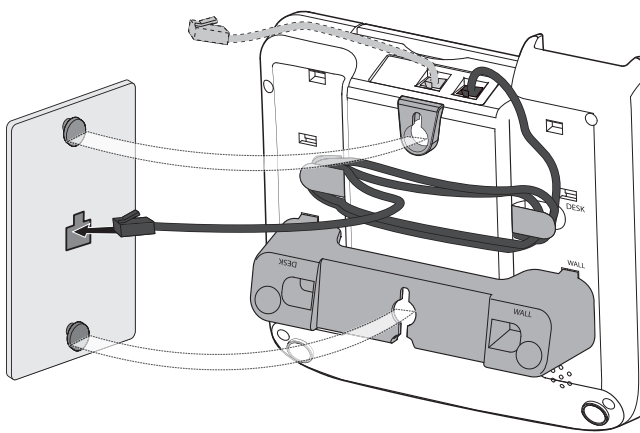

Base Layout

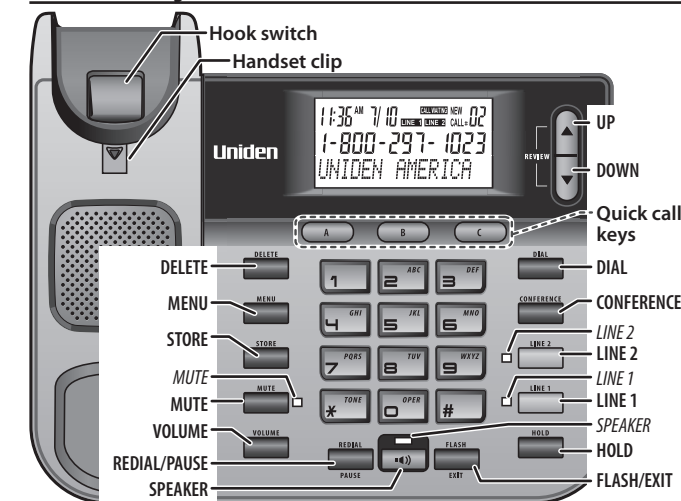

Setting Up the Phone

Using the Menu

- For best results, disconnect the telephone cord(s) from the wall jack(s) while using the setup menu.
- To open the setup menu, press **MENU**.
- Press **MENU** to scroll through the 4 menu screens detailed below.
- On each screen, use **UP** or **DOWN** to select the desired setting.
- Press **Menu** again to save the setting.
- If you don't press any buttons for 20 seconds, the phone exits the menu.

Setting the display language (ENG FRA ESP)

Use this screen to change the display language from English to French or Spanish.

- 1) Press **MENU** until **ENG FRA ESP** shows in the display.
- 2) Use **UP** or **DOWN** to select **ENG**, **FRA** or **ESP**.
- 3) Press **MENU** to save.

Setting the display contrast (CONTRAST)

Use this screen to adjust the contrast of the display.

- 1) Press **MENU** until **CONTRAST** shows in the display.
- 2) Use **UP** or **DOWN** to select level 1, 2, 3, 4, or 5. (The default setting is 3.)
- 3) Press **MENU** to save.

Setting your local area code (LOCAL AREA CODE)

The telephone uses the programmed area code to determine the number format to display when a valid Caller ID message is received. Numbers that match the local area code are displayed as seven digits and are used for dialing back previous numbers. Entering your local area code will also help you immediately know if the call is local or long distance when viewing the CID records in the display.

If you make a mistake and want to start over again, press DELETE to delete all of the digits.

- 1) Press **MENU** until **LOCAL AREA CODE** shows in the display.
- 2) Use the number pad to enter your three-digit area code.
- 3) Press **MENU** to save.

Setting the dial mode (TONE/PULSE)

Use this screen to change from touch-tone to pulse (rotary) dialing.

- 1) Press **MENU** until **TONE/PULSE** shows in the display.
- 2) Press **UP** or **DOWN** until the display shows the dialing mode you want to use.
- 3) Press **MENU** to save.

Completing Set-up

- When you are satisfied with the phone's configuration, press **Menu** (or wait 20 seconds for the phone to automatically exit the menu).
- Reconnect the telephone cord(s) to the wall jack(s).
- After set up, the phone will program the time and date automatically when it receives a valid Caller ID message.

Telephone Basics

You can use the telephone by speaking into and listening through the handset, or by using the speakerphone feature. For all operations, either Line 1 or 2 button must be pressed. Do not press both buttons down at the same time.

Making a Phone Call

- 1) Press **LINE 1** or **LINE 2**.
- 2) Pick up the handset or press **SPEAKER** to use the speakerphone.
- 3) When you hear the dial tone, dial the number you want to call.

OR

- 1) Dial the number.
- 2) Press **LINE 1** or **LINE 2**, then pick up the handset or press **SPEAKER**.

Receiving a Phone Call

When a call comes in, the **LINE 1** or **LINE 2** indicator light flashes next to let you know which line is ringing. To answer the call:

- 1) Press the button (**LINE 1** or **LINE 2**) next to the flashing light.
- 2) Pick up the handset, or press **SPEAKER**.

Hanging up

Replace the handset in the cradle, or press **SPEAKER** if you are using the speakerphone.

Reading the Line Status Indicators

This two-line phone is designed for use at multiple stations. The **LINE 1** and **LINE 2** indicator lights tell you what is happening on each line.

Light status	Display icon status	Meaning
Off	Off	The line is not in use.
Flashing red	Off	A call is being received.
Green	On	The line is in use by this phone.
Red	Flashing	A call is on hold.
Off	Flashing	An extension phone is using the line.
Off	Flashing	Line not connected.

Adjusting the Handset Volume

The volume controls for the handset and speakerphone are separate, so you can adjust one without affecting the other.

- 1) Pick up the handset and press **VOLUME REC** (handset receiver) shows in the display.
- 2) Press **UP** to increase the volume or **DOWN** to lower the volume. The handset's volume level setting will be saved in memory.

Placing a Call While Talking on Another Line

To place a call without hanging up on the first call:

- 1) Press **HOLD** to put the first call on hold.
- 2) Press the available line button to get a dial tone. Press **SPEAKER** if the speakerphone indicator is off and you are using the speakerphone.
- 3) Dial the number you want to call.

Receiving A Call While Talking on Another Line

When you receive a call while you are talking on another line, you will hear the phone ring.

- 1) Press **HOLD** to put the first call on hold.
- 2) Press the button (**LINE 1** or **LINE 2**) of the ringing line.
- 3) If the speakerphone indicator is off and you are using the speakerphone, press **SPEAKER**.

If you don't put the first call on hold, the phone will disconnect that call when you switch to the other line.

Using the Speakerphone

You must have batteries installed to use the speakerphone..

- During a normal call, simply press **SPEAKER** and place the handset in the cradle to switch to the speakerphone.

- The *SPEAKER* indicator light comes on when the speakerphone is in use.
- To stop using the speakerphone., just pick up the handset.
- In most procedures in this manual, you can also press *SPEAKER* to use the speakerphone wherever the instructions tell you to pick up the handset.

Adjusting the speakerphone volume

- 1) While using the speakerphone, press *VOLUME*. *SPK* (speakerphone mode) shows in the display.
- 2) Press *UP* to increase the volume or *DOWN* to lower the volume. The speakerphone volume level setting will be saved in memory.

Things to remember while using the speakerphone

- The speakerphone works similar to a two-way radio: you can listen or talk, but not both at the same time.
- When using the speakerphone, position yourself close to the phone so the caller can hear you clearly.

For best speakerphone performance, avoid the following:

- Areas with high background noise. (The microphone might pick up these sounds and prevent the speakerphone from going into the receiving mode when you finish talking.)
- Surfaces affected by vibration.
- Recessed areas such as in a corner, under a cupboard, or next to a cabinet, which can generate an echo effect.

Additional Telephone Features

Redial

You may redial the last number you called by pressing *REDIAL/PAUSE* after you hear a dial tone.

The redial feature holds the last number (up to 32 digits) that you dialed in memory. If you pressed any other numbers after dialing the phone number (for example, when accessing a voice-menu system) then those numbers are also dialed.

If you get a busy signal, press *REDIAL/PAUSE* again without hanging up.

Hold

Hold allows you to suspend the active line(s) and replace the handset in the cradle without hanging up, then resume the conversation on the same phone or from a different phone connected to the same line.

- 1) Press *HOLD* to place a call on hold (the line indicator is red).
- 2) Press *LINE* and pickup the handset or press *SPEAKER* to resume the conversation.

Conference Calls

You can use the conference call feature when you have calls on both lines and want to have a three-way conversation.

To connect and conference:

- 1) Call the first party.
- 2) Press *HOLD* to put the first party on hold.
- 3) Switch to the other line and call the second party (or answer an incoming call).
- 4) Press *CONFERENCE*. You will be able to speak with both parties.

To disconnect one party

Press the button for the line you want to continue talking to; the other call will automatically be disconnected.

To disconnect both parties

Hang up the handset or press *SPEAKER*.

To end the conference call without disconnecting either party

- 1) Press *HOLD* to put both parties on hold.
- 2) To speak to a party individually, press the button for the line that party is calling on; the second party remains on hold.

- To switch to the other party, press *HOLD* followed by the button for the other line.

- To restart the conference, put both lines on hold and press *CONFERENCE*. Pick up the handset or press *SPEAKER*.

Flash

Press *FLASH/EXIT* to activate special features of your telephone network, such as call transfer, or special services from your local telephone company, such as call waiting.

Mute

Use *MUTE* to interrupt a phone conversation to talk privately with someone else in the room. A conversation can be muted while using the speakerphone or handset.

- 1) Press *MUTE*. The mute indicator comes on.
- 2) Press Mute again to turn it off.

Temporary Tone Dialing

If you have pulse (rotary) service and want to access customer calling services (such as telebanking and long distance services) that require tone dialing, you can use this feature to temporarily change from pulse to tone service.

After dialing the telephone number and connecting to the customer calling service,

- 1) Press and release **/TONE*.
- 2) When you hang up, the telephone automatically returns to pulse dialing mode.

TIP: Temporary Tone can also be used while storing numbers in memory by pressing **/TONE* at the necessary point in the storage sequence.

Caller ID Features

In order to use the features in this section, you must subscribe to two separate services available from your local telephone company: the standard Name/Number Caller ID Service to know who is calling when the phone rings and Caller ID with Call Waiting Service to know who is calling while you are on the phone.

A timer (10 seconds on-hook and 3 seconds off-hook) located in the upper right side of the display will start, letting you know how much time is left until the unit returns to the Summary Screen.

Summary Screen

The Summary Screen shows the current time, date, and number of new calls to review. It is displayed until any button is pressed.

Receiving and Storing Calls

This unit receives and displays information transmitted by your local phone company. This information can include the phone number, date, and time; or the name, phone number, date, and time. The unit can store up to 75 calls for later review. When the memory is full, a new call automatically replaces the oldest call in memory. *NEW* appears in the display for calls received that have not been reviewed.

Reviewing Call Records

- Press *UP* or *DOWN* to view the call records.

- Press *UP* to scroll through the call records from the oldest to the newest.

- Press *DOWN* to scroll through the records from the newest one to the oldest.

- When all of the records have been viewed, *START/END* appears in the display.

Deleting Call Records

- To delete the record shown in the display, press *DELETE* once.
- To delete all records while reviewing, press and hold *DELETE* for about three seconds. *DELETE ALL?* appears in the display. Press Delete again to complete.

Dialing Back

When reviewing Caller ID records, you can dialback the numbers shown on the display by pressing *DIAL*.

If you did not program your local area code in the set-up menu, all numbers will be 10 digits.

- 1) Use *UP* or *DOWN* to display the number you want to dial. If the number has only seven digits (i.e. 555-1234), then the call came from within your area code; however, this does not guarantee the number is a local call. If the number has 10 digits, then the call is not from within your area code; however, this does necessarily mean the number is a toll call.
- 2) Press *DIAL*. The phone will start a 10-second countdown in the upper right corner of the display. (If the phone is already off hook, the countdown is only 3 seconds.)
- 3) If the phone displays *ADJUST* or *PICKUP OR ADJ*, you can adjust the phone number format. Press *DIAL* repeatedly to scroll through the available formats:

Digits	Format
7	7-digit telephone number (i.e. 555-5555)
10	3-digit area code + 7-digit telephone number (i.e. 425-555-5555)
11	long distance code 1 + 3-digit area code + 7-digit telephone number (i.e. 1-425-555-5555)

If the phone displays *PICKUP PHONE*, you can't adjust the phone number.

- 4) When you see the correct phone number format, press *LINE 1* or *LINE 2*.

- 5) Pick up the handset or press *SPEAKER* to dial the displayed number. *NOW DIALING* shows in the display and the number is dialed.

If you don't pick up the handset or press *SPEAKER* before the 10-second countdown ends, the phone times out and returns to the summary screen.

If the phone was already off hook when the countdown starts, the phone dials the number in the display when the 3-second countdown ends.

Caller ID Display Messages

The following special messages indicate the status of a message or the unit:

BLOCKED CALL	The caller of the incoming call is registered as "Private Number" and their Caller ID information is withheld.
CALL WAITING	Indicates a call is waiting on the line.
LOW	Battery power level is low.
NO CALLS	The caller memory is empty.
START/END	You are at the beginning or the end of the Caller ID memory log.
UNKNOWN CALLER	The incoming call does not have Caller ID service or their service area is not linked to yours. If UNKNOWN CALLER appears along with a calling number, the name information for that number was not available.

Memory

You may store information in any of the following memory locations: 0 to 9, A, B, and C keys.*

Storing a Name and Number in Memory

- 1) Press *STORE*. *LOCATION?* shows in the display.
- 2) Press the desired memory location (0 through 9, A, B, or C), or use *UP* or *DOWN* to scroll through the memory locations. If you need to erase an existing number, press *DELETE*.
- 3) Press *STORE* again to confirm the memory location.
- 4) Use the number keys to enter the telephone number (up to 32 digits) and press *STORE* to save. (The unit will not dial a phone number in this mode.) The cursor automatically moves to the text line for name entry. If you make a mistake, press *DELETE*.
- 5) If you need the phone to pause before sending the next numbers in the dialing sequence, press *REDIAL/PAUSE* (see "Storing a Pause in Memory" for more details).
- 6) Use the number keys to enter the name of the person associated with the telephone number you just entered (see Entering Text on Your Phone", below).
- 7) Press *STORE* to save the name.
- 8) To enter another name and number in a different memory location, return to step 1 and repeat the process.

Entering text on your phone

- To enter letters on your phone, refer to the letters in the top right corner of each number key; press the number key once for the first letter, twice for the second letter, etc.
- The flashing cursor automatically moves to the next position; you can also press *DOWN* to move the cursor to the next position.

For example, to enter the name *BILL S*:

- 1) Press 2 twice to enter the letter *B*.
- 2) Press 4 three times for the letter *I*.
- 3) Press 5 three times for the letter *L*.
- 4) Wait for the cursor to move to the next position or press *DOWN* to move the cursor.
- 5) Press 5 three times for the letter *L*.
- 6) To enter the space, press *DOWN* twice.

- 7) Press 7 four times for the letter *S*.

Editing or erasing a stored number

- 1) Press *STORE*. *LOCATION?* shows in the display.
- 2) Press the memory location (0 through 9, A, B, or C) you want to edit, or use *UP* or *DOWN* to scroll through the memory locations.
- 3) To erase the stored number, press *DELETE*. To edit the number, follow the procedure under "Storing A Name and Number in Memory" starting from step 4.

Copying Caller ID Records to Memory

- 1) Press *UP* or *DOWN* to view the caller number and name you want to copy.
- 2) Press *STORE*.
- 3) Press 0-9, A, B, or C for the memory location. The memory location flashes in the display if there is a record occupying that memory location. If you don't want to erase the existing entry, select another location.
- 4) Press *STORE* to save the number, and then press *STORE* again to edit the name.
- 5) Press *STORE* to confirm and save, and wait for three seconds to exit.

If the name you want to enter is longer than 12 characters, only the first 12 characters will be copied into memory.

Copying Redial Numbers to Memory

- 1) Press *REDIAL/PAUSE* while the phone is on-hook. The display shows *PICKUP PHONE*.
- 2) Press *STORE*.
- 3) Press 0-9, A, B, or C for the memory location. Press *STORE* twice to confirm the location and the number. The cursor flashes in the display and you may enter the caller's name.
- 4) Press *STORE* to confirm and save, and wait for three seconds to exit.

If you want to edit the number, press *STORE* within three seconds to enter the edit mode.

Storing a Pause in Memory

You can use *REDIAL/PAUSE* to insert a pause when you need the phone to delay in an automatic dialing sequence, for example, if you must dial a 9 to get an outside line or when you need to dial an extension number or access code.

You can adjust the length of the pause from 1 to 9 seconds in length. The default setting is 4 seconds.

- 1) Press *STORE*.
- 2) Press *REDIAL/PAUSE*. The current pause time displays.
- 3) Press *UP* or *DOWN* to scroll to the pause time, or press the 1 to 9 key for one second to nine seconds respectively (i.e.; 1 = one second, 2 = two seconds).
- 4) Press *STORE* to save.

Dialing a Number Stored in Memory

- 1) Press *LINE 1* or *LINE 2*.
- 2) Press *A*, *B*, or *C*, or press *DIAL* followed by the number key (0 - 9) that contains the number you want to dial. The stored number appears in the display.
- 3) To dial the displayed number, pick up the handset or press *SPEAKER*.

OR

- 1) Press *LINE 1* or *LINE 2*.
- 2) Pick up the handset or press *SPEAKER*.
- 3) When you hear the dial tone, press *A*, *B*, or *C*, or press *DIAL* followed by the number key (0 - 9) that contains the number you want to dial.

Chain Dialing

Chain dialing allows you to dial a sequence of stored numbers from separate memory locations, for example:

Sample information	Memory location
Local access number for long distance company	A
Authorization code ID	B
Long distance phone number	C

- 1) Press *LINE 1* or *LINE 2*.
- 2) Pick up the handset or press *SPEAKER*.
- 3) Press *A*.
- 4) Press *B*.
- 5) Press *C*.

Troubleshooting Tips

No dial tone

- You must press a line button to get a dial tone.
- Check all cabling to make sure that all connections are secure and not damaged.
- Check hook switch: does it fully extend when handset is lifted from cradle?

No display

- Replace batteries.
- Check for proper battery installation.

No information is shown after the phone rings

- Did you order caller id service from your local telephone company? This unit requires that you subscribe to caller id service in order to work.
- Be sure to wait until the second ring before answering.

Phone dials in pulse with tone service

- Make sure tone/pulse dial mode in the setup menu is set to tone dial.

Phone won't dial out with pulse service

- Make sure tone/pulse dial mode in the setup menu is set to pulse dial.

Phone does not ring

- Is the ringer switch in the off position?
- Are you using too many phones on one line? (The total REN of all phones on the same line should not be greater than the maximum REN for your calling area. See paragraph 1 of the equipment approval information section of this user's guide for more information).
- See "No dial tone".

Incoming voice volume low

- Are other phones off hook at same time? If so, this is normal condition as volume drops when additional phones are used at once.
- Check the handset or speaker volume.

Telephone continues to ring after handset is picked up or speaker button is pressed

- You must press the line number to answer a call.

Memory dialing doesn't work

- Make sure you entered the numbers correctly into memory.

General Product Care

To keep your phone working and looking good, follow these guidelines:

- Avoid putting it near heating appliances and devices that generate electrical noise (for example, motors or fluorescent lamps).
- DO NOT expose to direct sunlight or moisture.
- Avoid dropping and other rough treatment to the unit.
- Clean with a soft cloth.
- Never use a strong cleaning agent or abrasive powder because this will damage the finish.
- Retain the original packaging in case you need to ship it at a later date.

One-year Limited Warranty

Evidence of original purchase is required for warranty service.

WARRANTOR: UNIDEN AMERICA CORPORATION ("Uniden")

ELEMENTS OF WARRANTY: Uniden warrants, for one year, to the original retail owner, this Uniden Product to be free from defects in materials & craftsmanship with only the limitations or exclusions set out below.

WARRANTY DURATION: This warranty to the original user shall terminate & be of no further effect 12 months after the date of original retail sale. The warranty is invalid if the Product is (A) damaged or not maintained as reasonable or necessary, (B) modified, altered, or used as part of any conversion kits, subassemblies, or any configurations not sold by Uniden, (C) improperly installed, (D) serviced or repaired by someone other than an authorized Uniden service center for a defect or malfunction covered by this warranty, (E) used in any conjunction with equipment or parts or as part of any system not manufactured by Uniden, or (F) installed or programmed by anyone other than as detailed by the owner's manual for this product.

STATEMENT OF REMEDY: In the event that the product does not conform to this warranty at any time while this warranty is in effect, warrantor will either, at its option, repair or replace the defective unit & return it to you without charge for parts, service, or any other cost (except shipping & handling) incurred by warrantor or its representatives in connection with the performance of this warranty. Warrantor, at its option, may replace the unit with a new or refurbished unit. THE LIMITED WARRANTY SET FORTH ABOVE IS THE SOLE & ENTIRE WARRANTY PERTAINING TO THE PRODUCT & IS IN LIEU OF & EXCLUDES ALL OTHER WARRANTIES OF ANY NATURE WHATSOEVER, WHETHER EXPRESS, IMPLIED OR ARISING BY OPERATION OF LAW, INCLUDING, BUT NOT LIMITED TO ANY IMPLIED WARRANTIES OF MERCHANTABILITY OR FITNESS FOR A PARTICULAR PURPOSE. THIS WARRANTY DOES NOT COVER OR PROVIDE FOR THE REIMBURSEMENT OR PAYMENT OF INCIDENTAL OR CONSEQUENTIAL DAMAGES. Some states do not allow this exclusion or limitation of incidental or consequential damages so the above limitation or exclusion may not apply to you.

LEGAL REMEDIES: This warranty gives you specific legal rights, & you may also have other rights which vary from state to state. This warranty is void outside the United States of America & Canada.

PROCEDURE FOR OBTAINING PERFORMANCE OF WARRANTY: If, after following the instructions in the owner's manual you are certain that the Product is defective, pack the Product carefully (preferably in its original packaging). Disconnect the battery from the Product & separately secure the battery in its own separate packaging within the shipping carton. The Product should include all parts & accessories originally packaged with the Product. Include evidence of original purchase & a note describing the defect that has caused you to return it. The Product should be shipped freight prepaid, by traceable means, to warrantor at:

Uniden America Service
4700 Amon Carter Blvd.
Fort Worth, TX 76155

Uniden® is a registered trademark of Uniden America Corporation.

The pictures in this manual are used for examples only. Your actual phone may not look exactly like the pictures.